

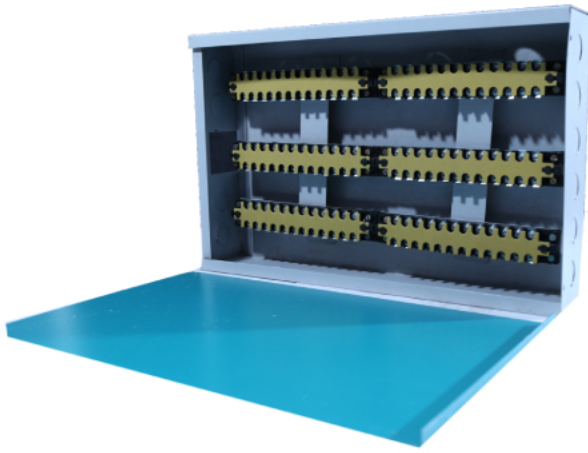

SMB

Elevators Manufacture & Installation

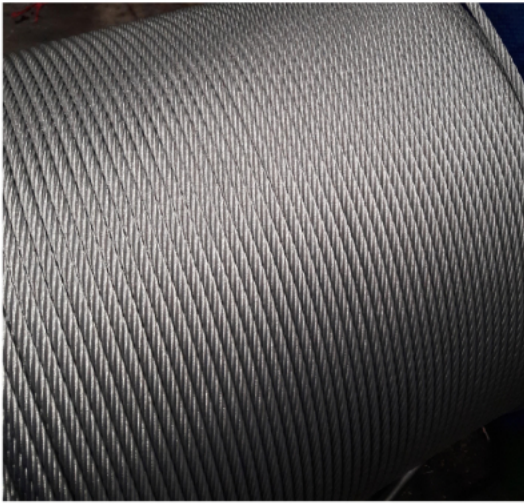





SN-CD-901 Economic Solution



SN-CD-902 Economic Solution



SN-CD-905 Luxury Solution

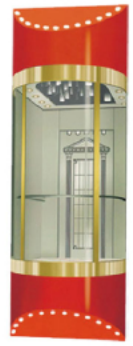

SN-CD-903 Luxury Solution

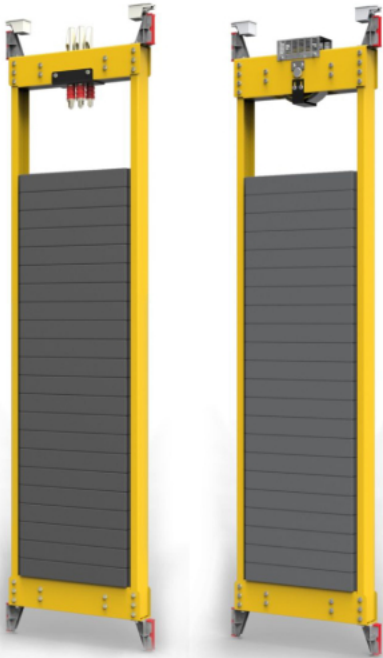

SN-CD-902 Luxury Solution



SN-CD-903 Luxury Solution



SN-CD-904 Luxury Solution



SN-CD-901 Luxury Solution

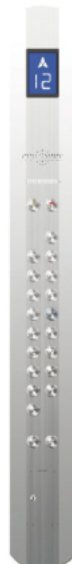

SN-COP-510



SN-COP-511



SN-COP-512



SN-COP-620



SN-COP-640



SN-COP-650



SN-COP-660



SN-COP-670



SN-COP-680



SN-COP-680



SN-COP-680





↑ Telescopic Auto Door

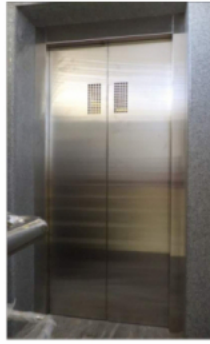

↑ Center Opening Auto Door (Small Vision)

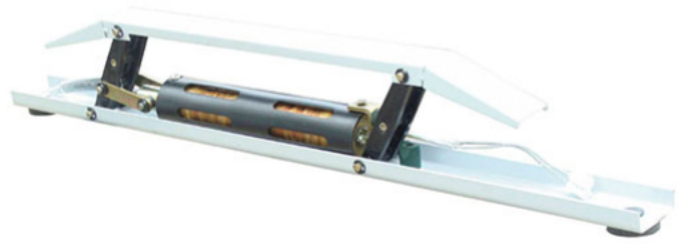

Full Frame Glass Auto Door →









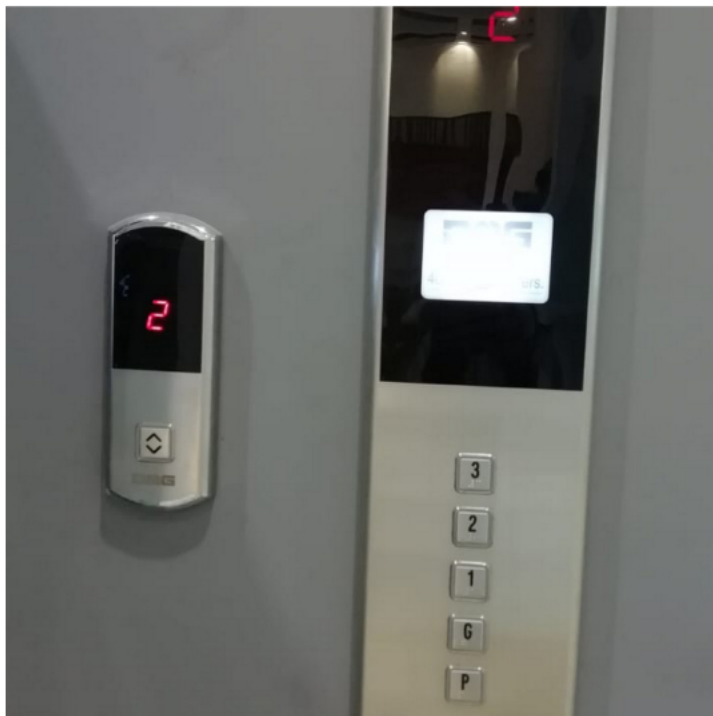

































Full Glass Auto Door →

Excellent
48 48 48

ECW-P1



					
NV1300	NV1506	NV1700	NV2100	NV2300	NV2400
					
NV4100	NV4200	NV5100	NV5700	NV5800	NV1F00
					
NV2J02	NV2K01	NVBN21F	NVBN401	NVBN432	NVBN531
					
NVBN53C	NVBN53F	NVBN541	NVBN552	NVBN590	NVBN631
					
NVBS101	NVBS10F	NVBS141	NVBS143	NVBS180	NVBS201
					
NVBS211	NVBS661	NVKF250	NVKF260	NVKN115	NVKN131
					
NVKN144	NVKN301	NVKS473	NVKS930		

Sheets Metal Fabrication Color Swatch



HL Rosegold



HL Gold

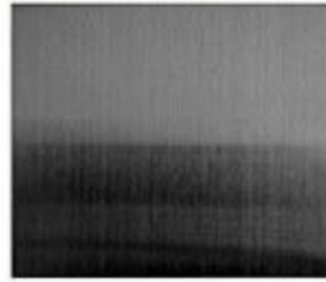

HL Black



HL Champagne



HL Brown



HL Antique Bronze



HL Yellow Gold



HL Bronze



HL Grey



Beadblast Anti finger



Beadblast Brown



Mirror Smoky



Mirror Etched Gold



Mirror Etched Bronze



Vibration Rosegold



Mirror Rosegold



HL B Brown



Mirror Black



HL B Black



Mirror Brown



KY-B001#
Main Power Switch



KY-B002#
Maintenance Rotary Switch



KY-B003#
Limit Switch GK



KY-B004#
Large Wheel Switch TV231



KY-B005#
Small Wheel Switch TV231



KY-B006#
Switch TV231



KY-B007#
Switch TR236



KY-B008#
Switch ZR236



KY-B009#
Switch ZS236



KY-B010#
Switch UKS/UKT



KY-B011#
Escalator Passageway Switch



KY-B012#
Switch 1375



KY-B013# OTIS Tension
Rope Pulley Switch AA3



KY-B014#
OTIS Governor Switch AA1



KY-B015#
OTIS Limit Switch 6098B3/B7



KY-B016#
OTIS Limit Switch 6098B11



Cable



Door



Integrated Elevator Controller



LOP



Light Curtain



Intercom



Guide Rail

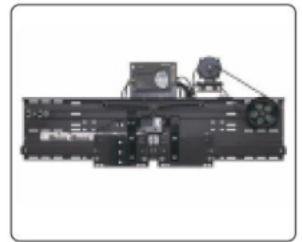

Door system



PM Traction machine



Geard Traction machine



Control Cabinet



Cop



Push Button



Display

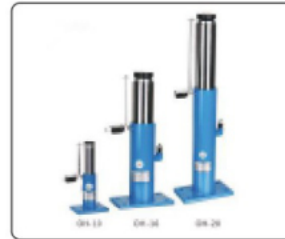

Oil buffer



Inspection box



Limit switch



Photo-electric switch



8K Mirror



HL



Brush



Beadblast



No.4

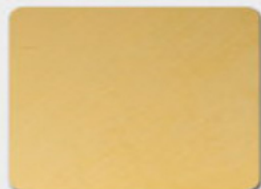

Mirror Gold

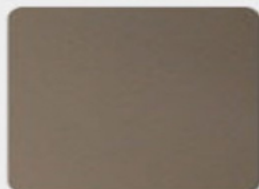

Mirror Smoky

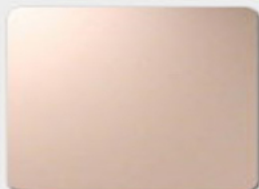

Mirror Rosegold



Mirror Wine



Mirror Y.Gold

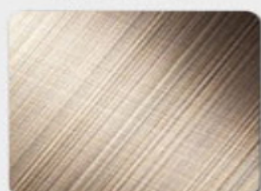

Cross HL Brown



Cross HL Wine



HL Black



HL Y.Gold



HL 6K



Beadblast Black

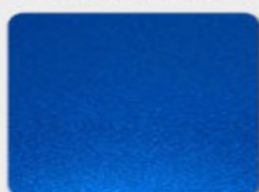

Beadblast Blue

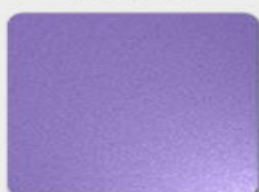

Beadblast Purple

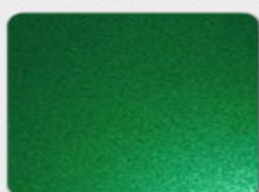

Beadblast Green

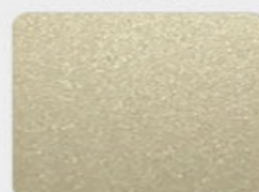

Beadblast Champagne



Vibration Gold

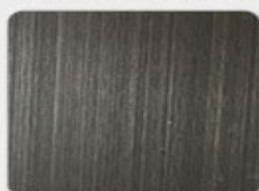

HL Black Bronze



HL Red Bronze



Vibration Blue

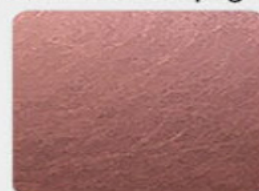

Vibration Wine

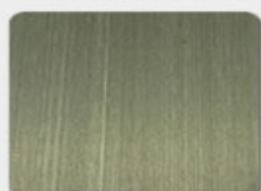

HL Antique Bronze

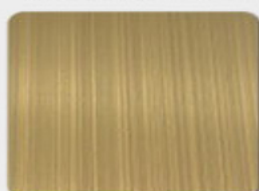

HL Yellow Bronze

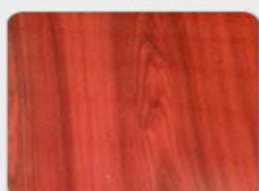

Lamination MM-A

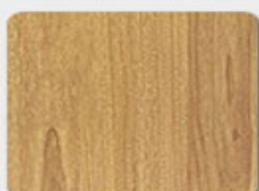

Lamination MM-B



Lamination MM-C

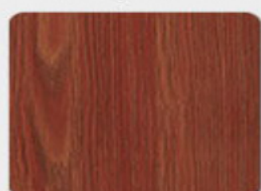

Lamination MM-D

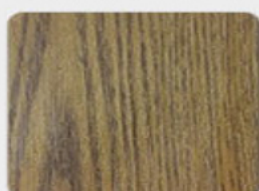

Lamination MM-E



Lamination MM-F

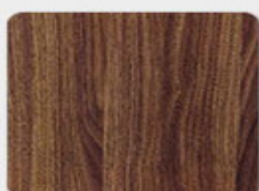

Lamination MM-G

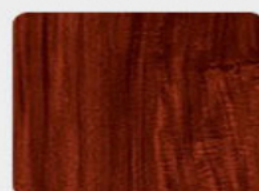

Lamination MM-H

Trachtion Lift Accessories



LL-160/160A



LL-160



101



102



Guide Shoe



Brackets



Door Brackets



Car Adjusting Brackets



WVF 5.5 kw, 7.5 kw, 11 kw



Traction Motor

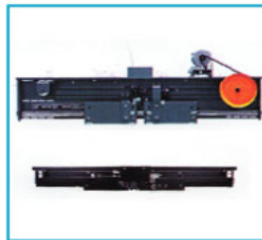

Door Operator + Hanger



Lift Controller



Inverters



Door Inverters

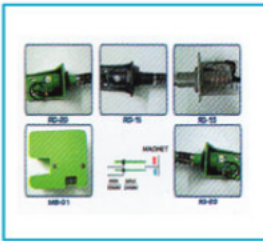

Bistable Magnetic switch



Full Height Photocell

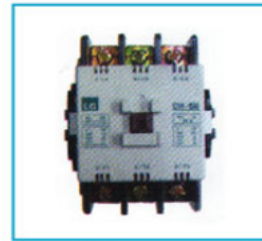

Magnetic Contactor

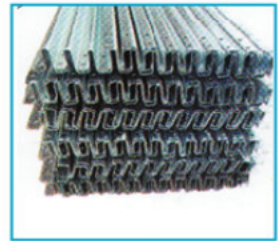

Guidrail



Guidrail



Traveling Cable



Traveling Cable



Sheave



Oil Buffer



Buffer Spring



S. Rope / S. Rod



Em. Brake



Rope Clip

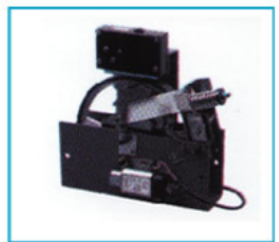

Speed Governor



Cross Fan



Anchor Bolt/Magnet Round Type/Encoder

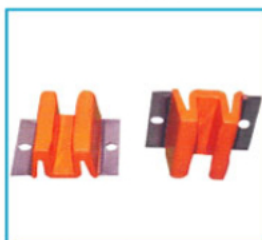

C.W.T Guide Shoe



Oil Pot



Intercom

M.S. CABIN



S.S. CABIN



CAPSULE DESIGN





MS Cabin



MS Cabin with Mirror



MS Cabin



SS Gold Mirror Design Cabin



SS Hair Line with Mirror finish Cabin



SS Hair Line Cabin

CABIN

The elevator cabin can make a big impression on passengers. It reflects the building's decor and your commitment to tenants' comfort.



Center Opening Auto Door



Center Opening Auto Door
(Half Vision)



Center Opening Auto Door
(Design)



Telescopic Auto Door
(Big Vision)



Center Opening Auto Door
(Big Vision)



Center Opening Auto Door
(Four Panel)

AUTOMATIC DOORS

The automatic doors at grocery stores and office buildings mainly exist for convenience. The automatic doors in an elevator, on the other hand, are absolutely essential they keep people from falling down an open shaft.

Elevators use two different sets of Doors: doors on the cars and cars and doors opening into the elevator shaft, the doors on the cars are operated by an electric motor, which in turn is operated by the elevator computer.

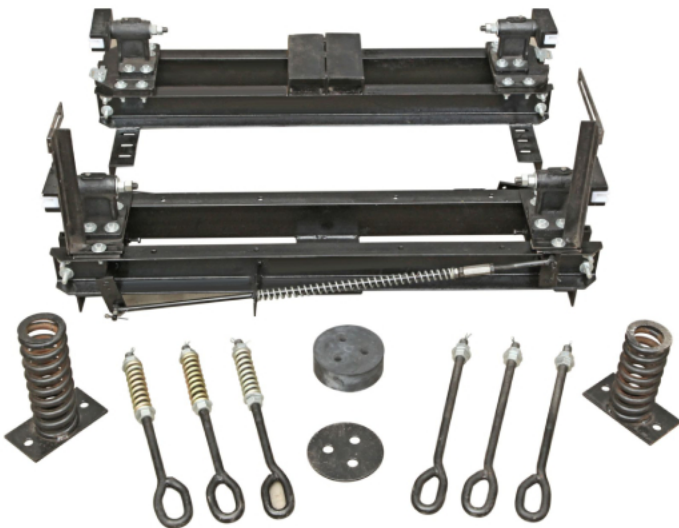

CAR & CWT FRAME



MR CAR FRAME 1:1



MRL CAR FRAME 2:1



MRL CAR FRAME 2:1
BOTTOM PULLEY



MRL CAR FRAME 2:1
PLUS TYPE ARRANGEMENT

CANTILEVER



CANTILEVER TRACTION



CANTILEVER HYDRAULIC

ACCESSORIES



INSTANTANEOUS SG



PROGRESSIVE SG

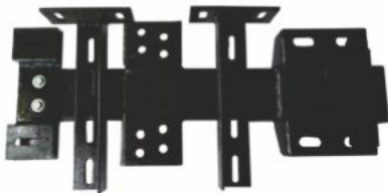

MACHINE MOUNTINGS



CAR & CWT PULLEY

CAR FRAMES
CANTILEVERS



ENGINEERED
FOR SAFETY

www.bharatelevator.in

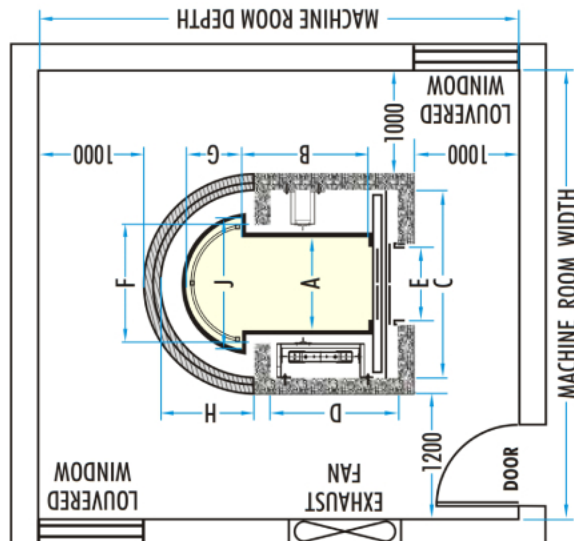

Elevator Component (GEARED)

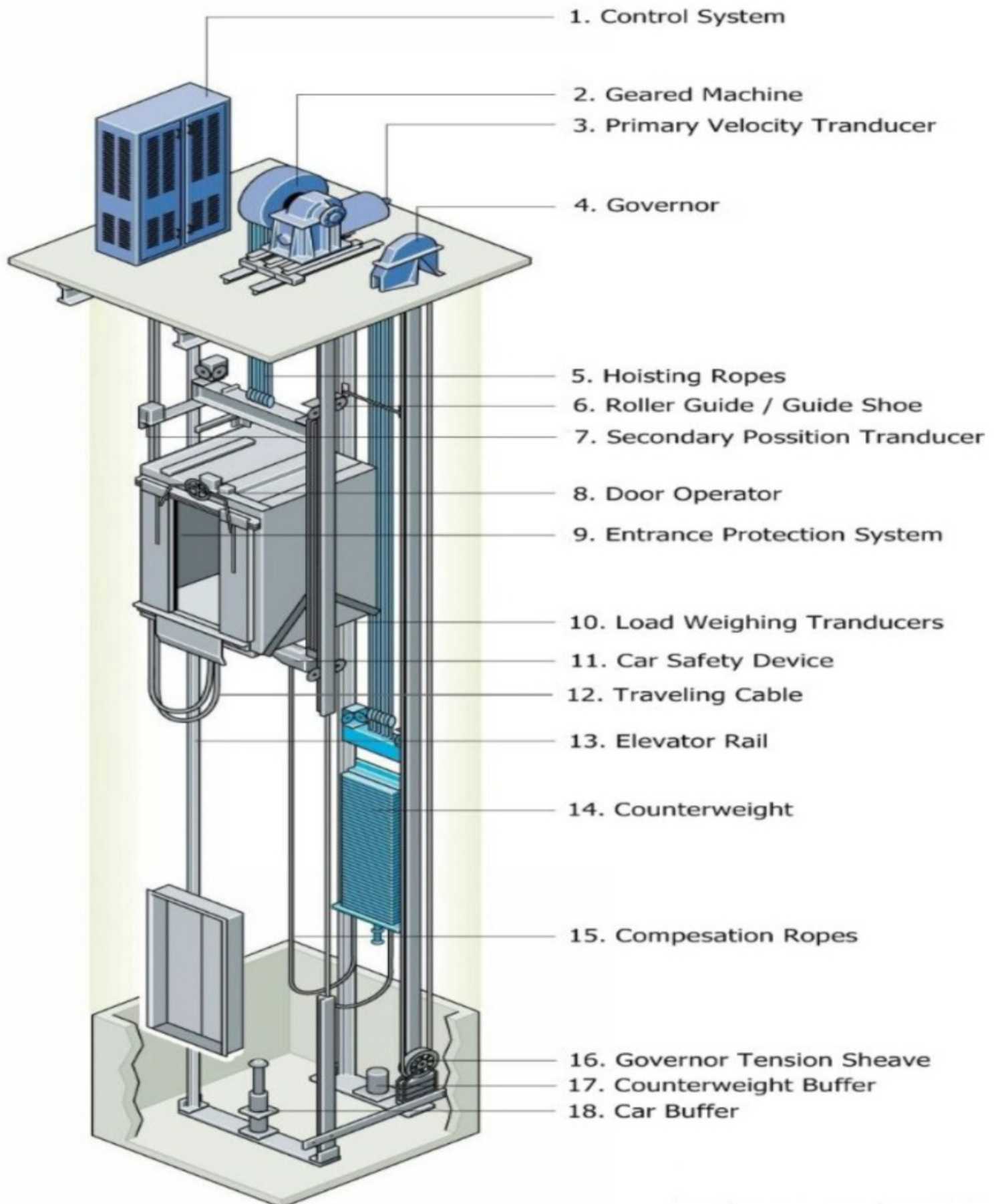

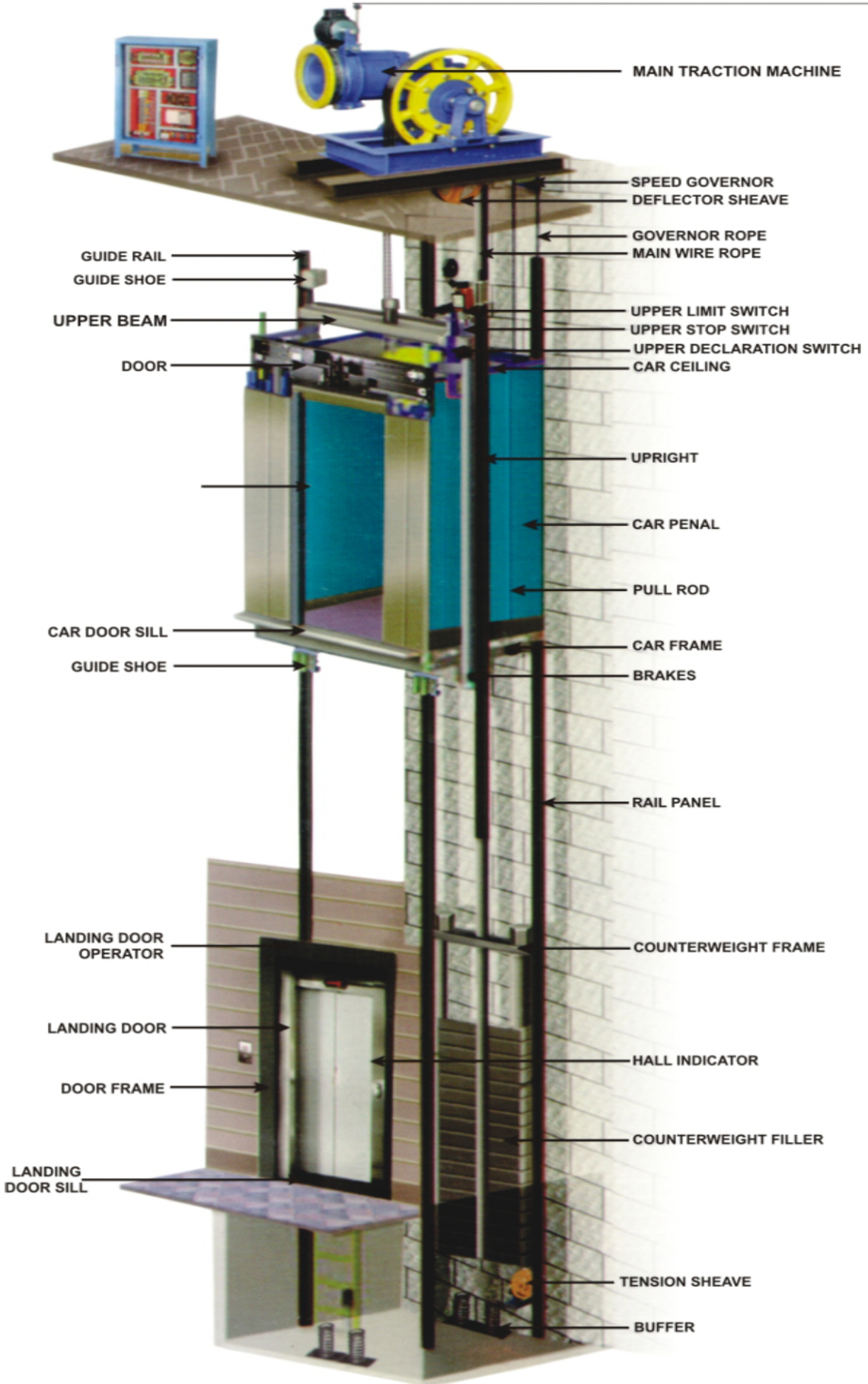

30 Feet

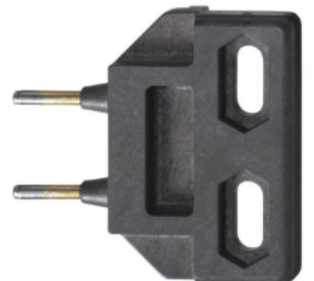
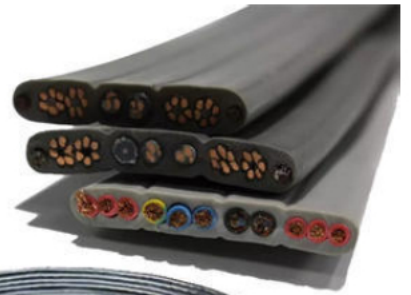
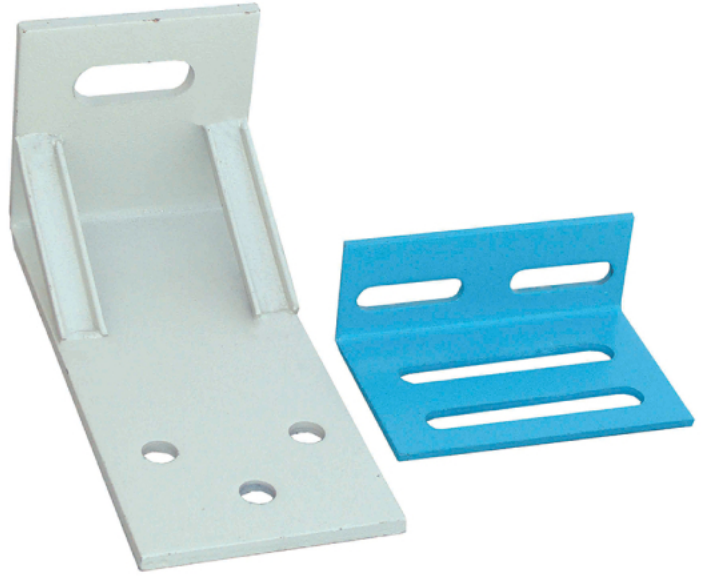

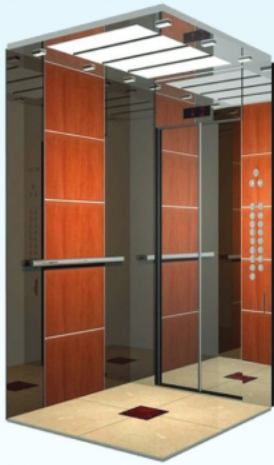

MS Cabin



Gold Cabin

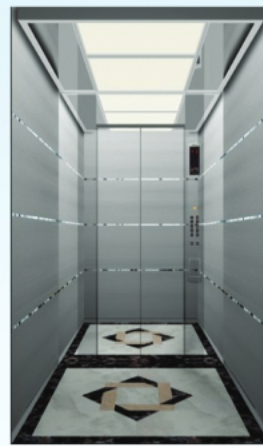

SS Cabin



Bed Cabin



Goods Cabin



Imperforated Door



Spring Door



Manual Door



Big Vision Glass Door



MS Telescopic Door



MS Auto Door



SS Auto Door



Sharp Motor

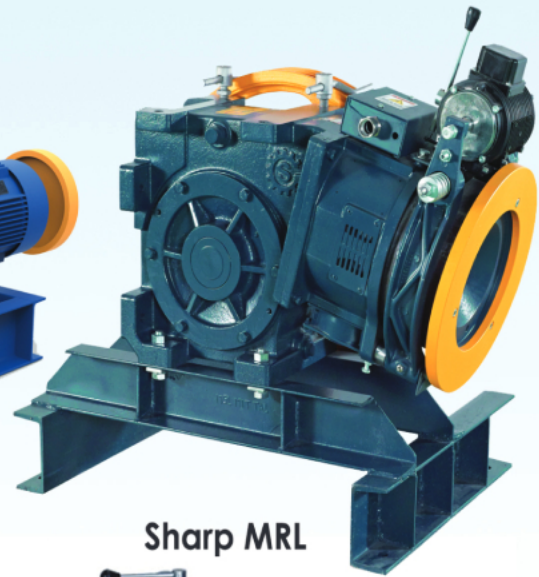

Sharp MRL

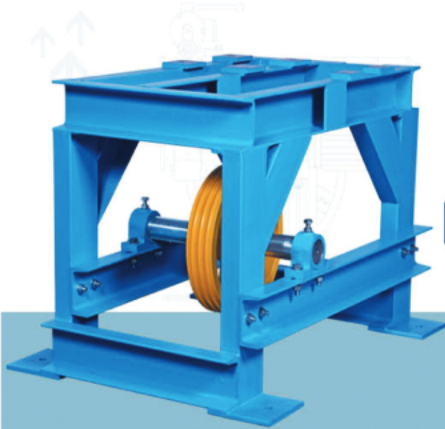

RL 7, 8, 9

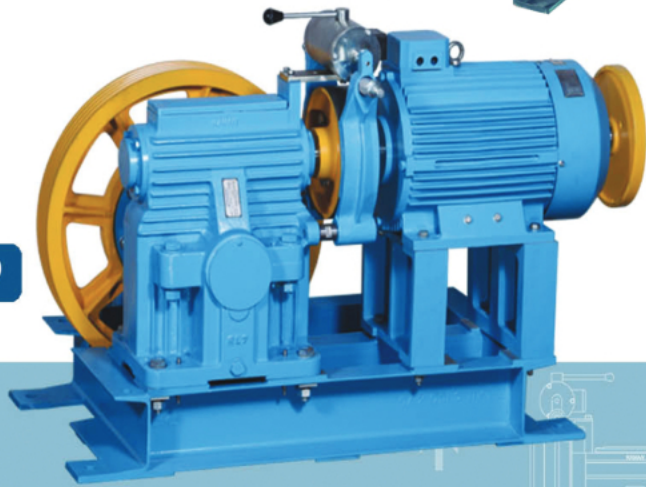

Raman Motor

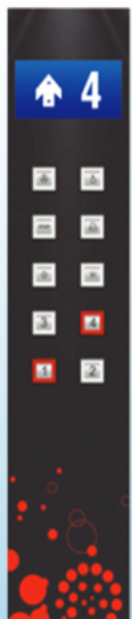

COP

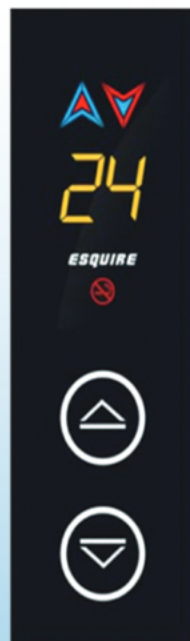

Multi colour LOP



JADE LOP



What could have happened

In the final investigation report, an authorised examiner reconstructs how the doors of a lift at Block 322, Tah Ching Road, might have severed the hand of Madam Khoo Bee Hua

As Madam Khoo enters

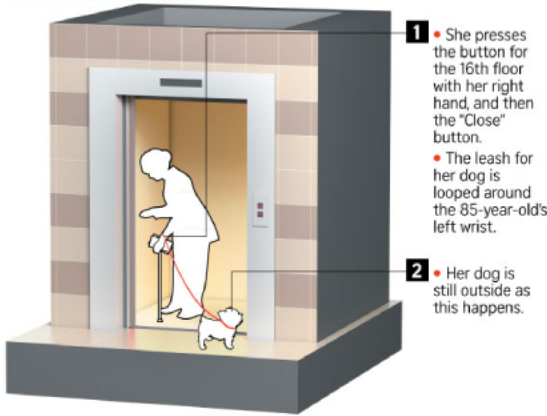

- 1** • She presses the button for the 16th floor with her right hand, and then the "Close" button.
 - The leash for her dog is looped around the 85-year-old's left wrist.
- 2** • Her dog is still outside as this happens.

Doors close



- 3** • The 2mm-thick leash is too narrow to activate lift sensors that would have reopened the doors.
 - Instead it is caught in between.

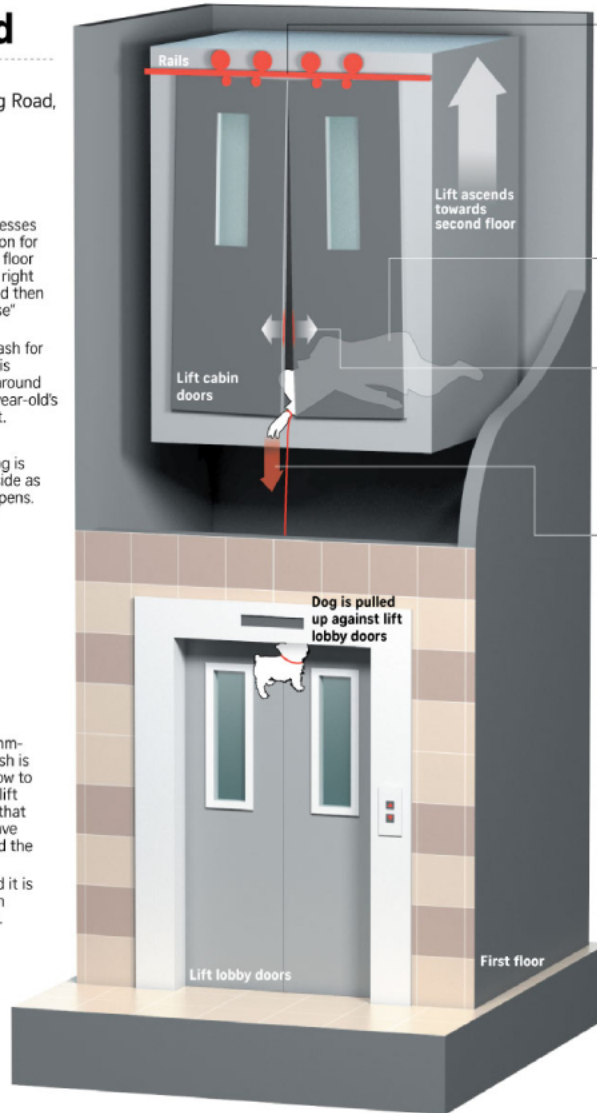

The Fulcrum Effect

- The lift cabin doors are hung from rails at the top.
- If a significant force is applied to the bottom of the lift cabin doors while they are closed, it is possible for the doors to be prised open slightly.
- The gap would be narrowest at the top and widest at the bottom, forming a slim A-shape opening.

Lift ascends

- 4** • As the lift rises, the leash around Madam Khoo's wrist tightens. She is pulled to the floor. The dog is also pulled up against the lift lobby doors till its harness buckle is caught at the top part of the lift lobby door.
- 5** • The pull of the taut leash against the lift doors forces them apart slightly, opening up a small gap at the base.
 - As the lift continues to go up, the force of the leash is strong enough to pull Madam Khoo's left hand through this small gap.
 - The hand widens the gap, triggering the lift to come to a gradual emergency stop.
- 6** • The hand is crushed and severed between the lift cabin doors and the internal parts of the lift lobby doors. This happens near the second floor landing.
 - The lift stops near the third floor. The severed hand falls to the bottom of the lift pit.

Safety features of the lift at Block 322

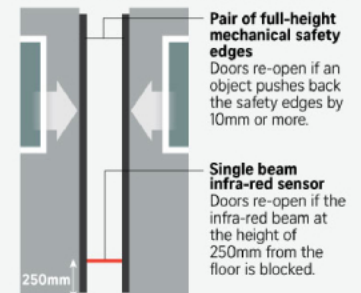

Why doors did not re-open
The devices were not designed to detect obstructions that are too thin, such as a 2mm-thick dog leash.

Persons	Persons	Car Inside	Lift Shaft Size	Entrance	Machine Room
	Load		(Two side open)		
No.	Kg.	Width x Length	Width x Length	Width	Width & Length
4	272	1100 X 700	1600 X 1300	900	3000 X 3000
6	408	1100 X 1000	1600 X 1600	1000	3000 X 3000
8	544	1300 X 1100	1800 X 1700	1100	3000 X 3000
10	680	1350 X 1300	1850 X 1700	1350	3000 X 3000
13	884	2000 X 1100	2500 X 1700	1350	3000 X 3000
16	1088	2000 X 1300	2500 X 1900	1500	3000 X 3000

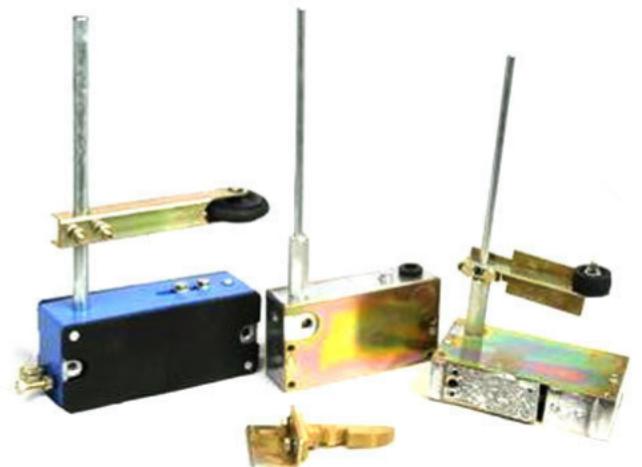
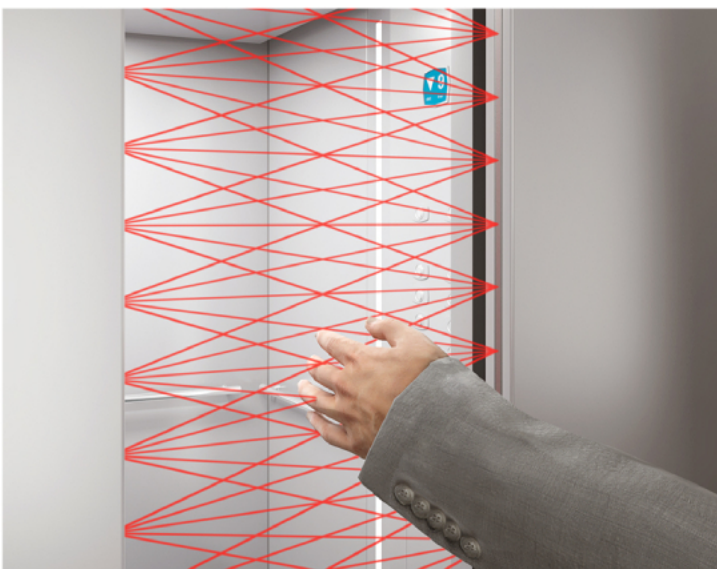
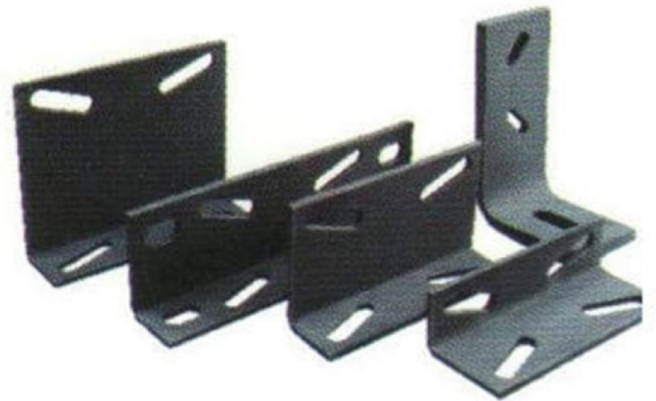
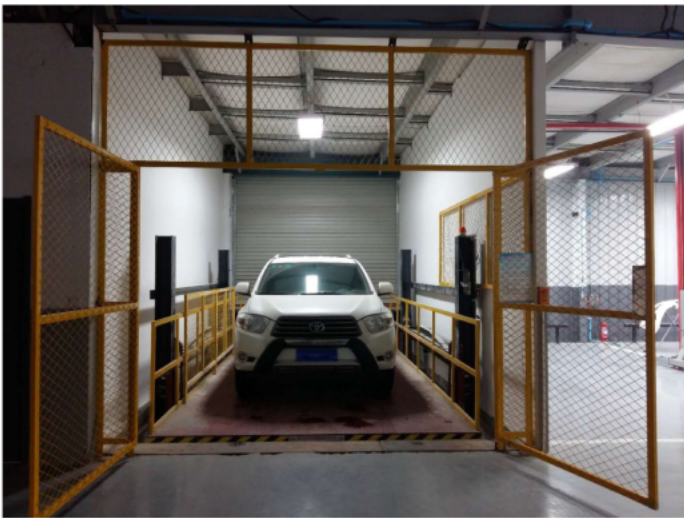



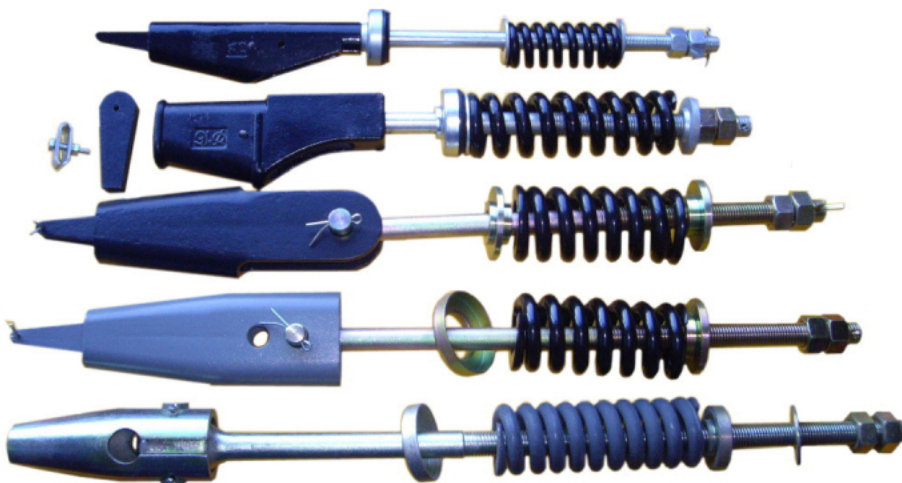
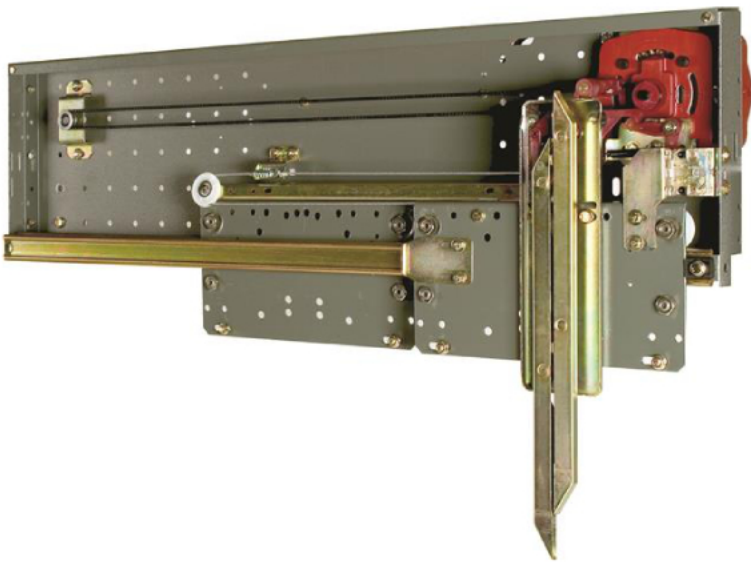

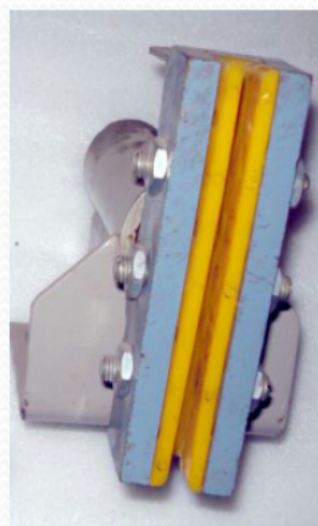
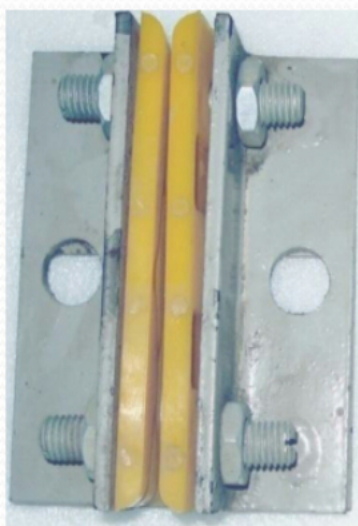
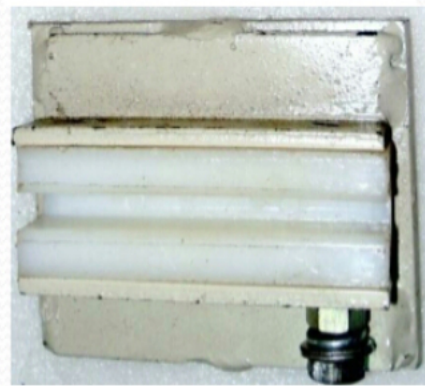
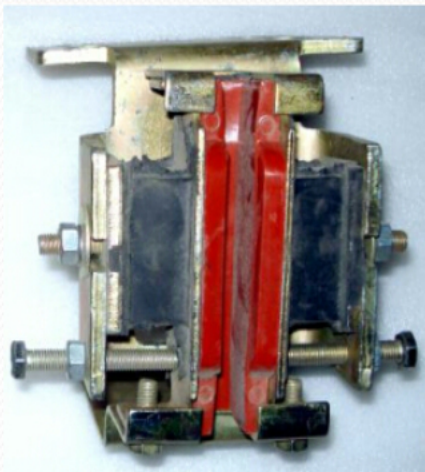

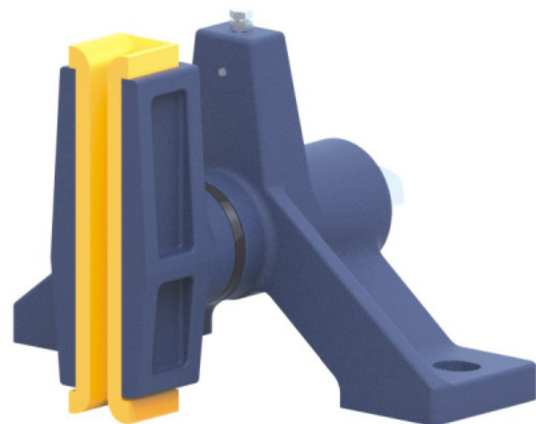
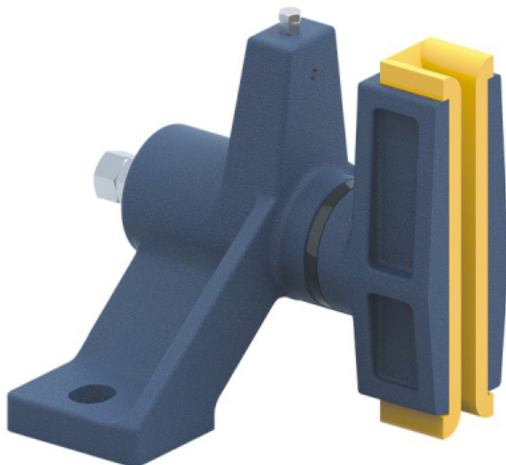
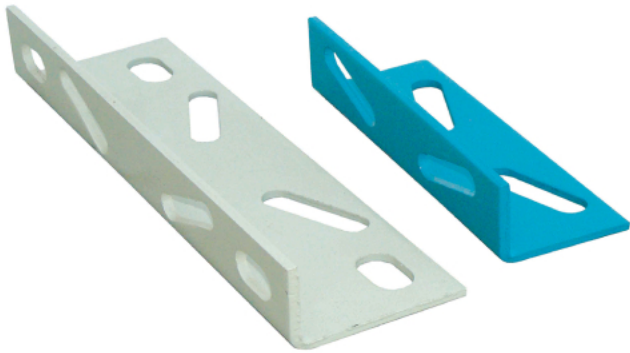

C
A
B
I
N
S



MS POWDER COATED



SS HAIR LINE



SS MIRROR CABIN



SS GOLD MIRROR

D
O
O
R
T
Y
P
E
S



COLLAPSIBLE GATE



IMP MANUAL DOOR



SWING DOOR



TMD



AUTO DOOR



FRAMED GLASS DOOR

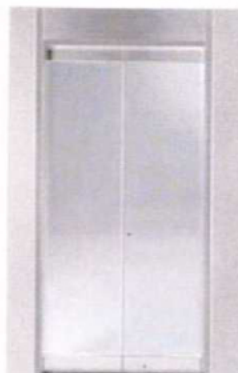

FULL GLASS DOOR



VISION AUTO DOOR

- ☐ Cabins are manufactured as per the customer requirement.
- ☐ Panel finish with multiple choice.

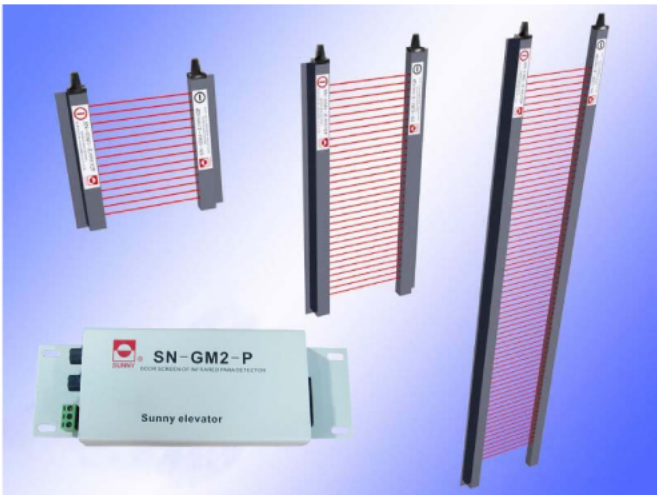
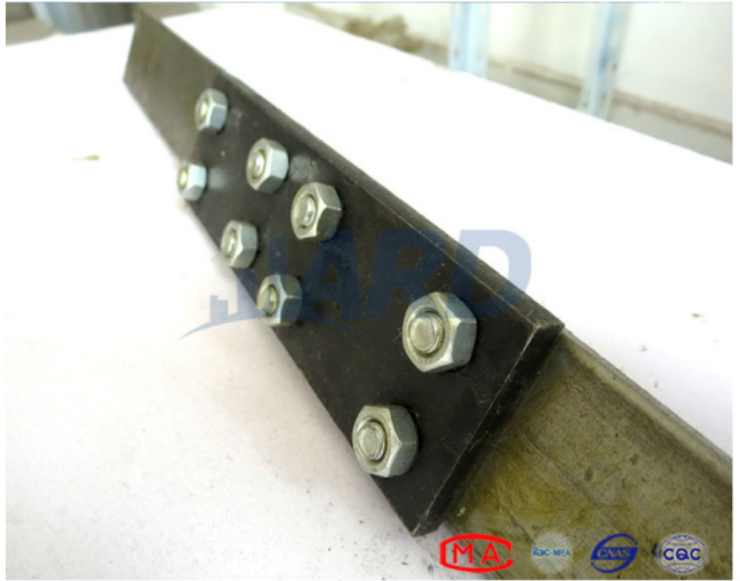

 YS-FS-15601

 YS-FS-15602

 YS-FS-15603

 YS-FS-15604

 YS-FS-15605

 YS-FS-15606

 YS-FS-15601

 YS-FS-15607

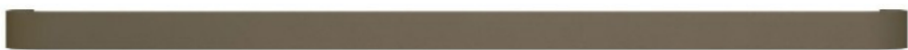
 YS-FS-15609

 uview.en.alibaba.com YS-FS-15610

 YS-FS-15611

 YS-FS-15612

 YS-FS-15613

 YS-FS-15614

 YS-FS-15615

 YS-FS-15616

 YS-FS-15617

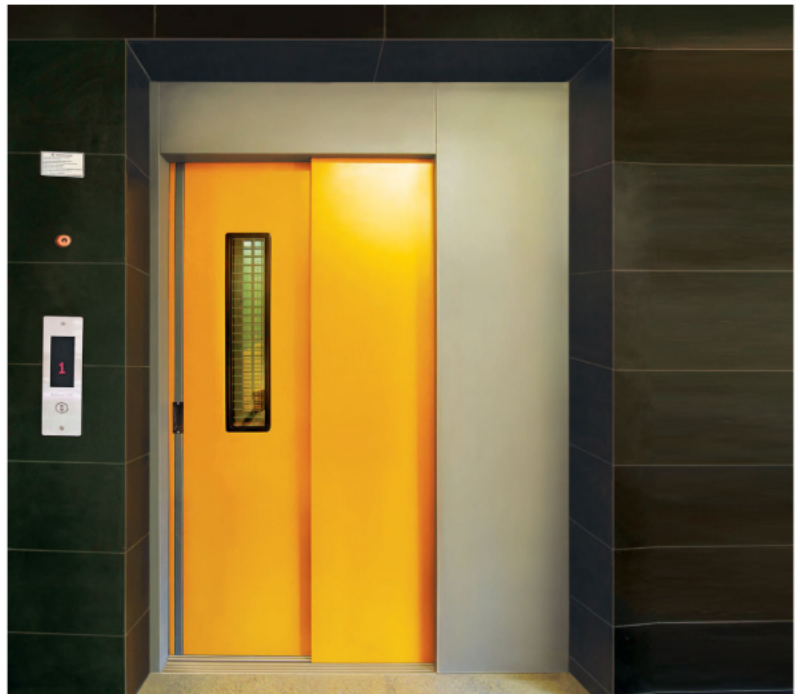
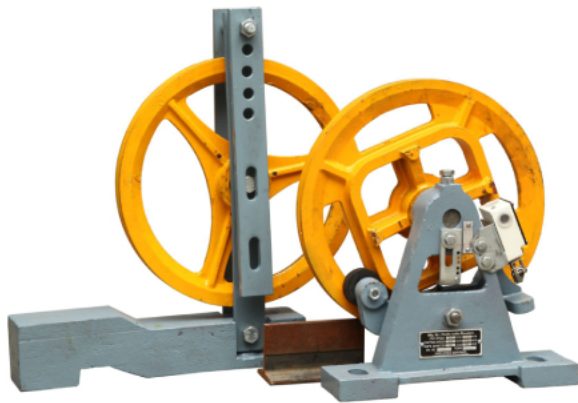

Other Components

 Sensor	 Open Close	 F7 G7 VARIABLE FREQUENCY AC DRIVE	 Standard Usha Martin Elevator Rope
 Elevator T Guide Rail	 Inspection Box	 Limit Switch	 Tension Type Sensing



High-performance
small sized PMSM
traction machine



Roller guide



New lightweight car



Car design: PRM-1

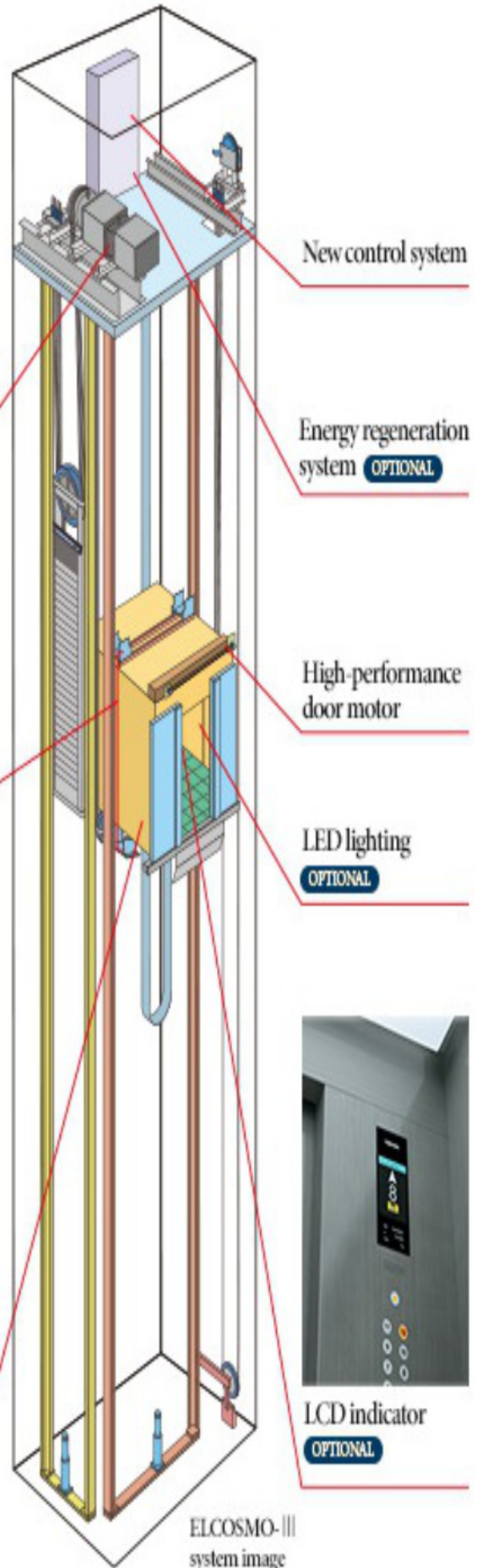

Actual product colors may vary slightly from the printed colors in this catalogue.

ELEVATOR SPARES - 1



THIMBLE



ROPE ATTACHMENTS



BRICK FASTENERS



WIRE/BULL DOG CLIPS



RCC FASTENERS

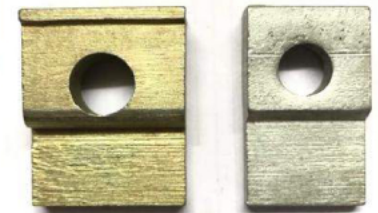

GUIDE CLIP- SAPING



GUIDE CLIP- SHEET TYPE



CABLE HANGER-MS

RETIRING CAM- For Manual Collapsible Door

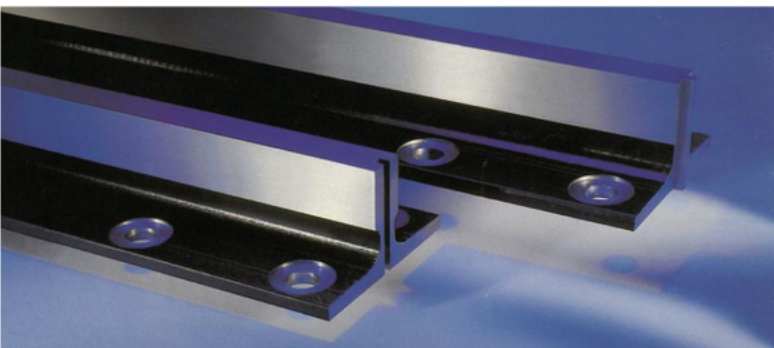

OFF. : Near Vaatika Residency Chachiyawas, Sikar Road (Ajmer), 305023

Email : Smbelevators@gmail.com

Phone : 9828676926, 9664402203

Website : www.smbelevators.com